

Art. Nr.: **SB.6541133**

Bezeichnung: **65411**

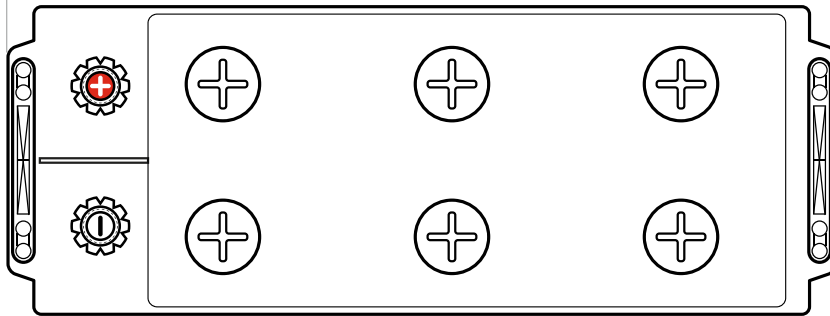
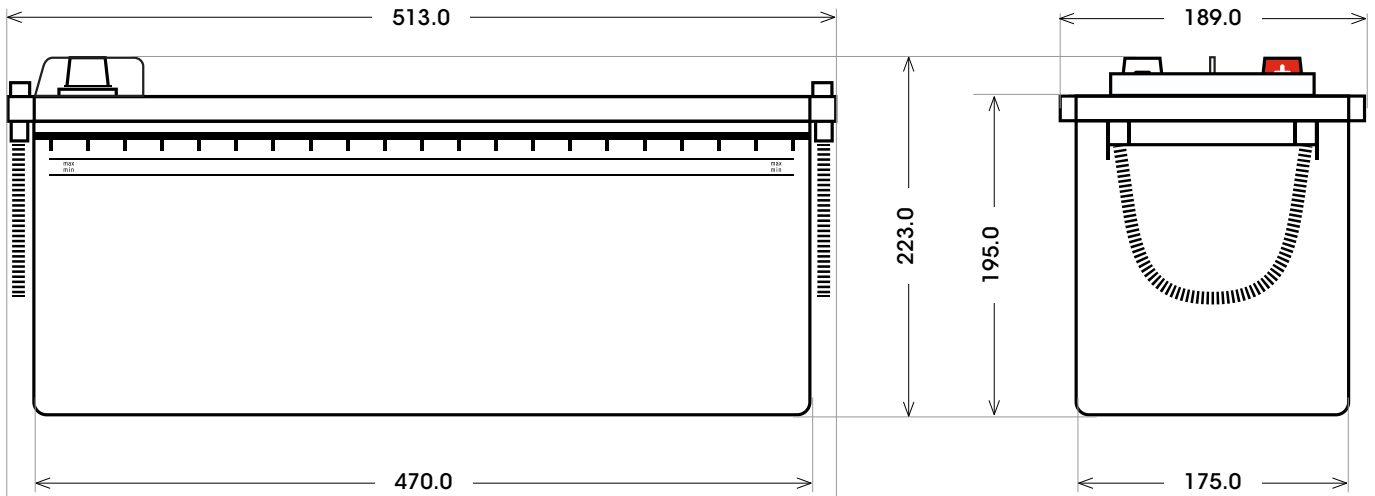

Technologie	Calcium-Calcium
Separator Typ	Envelope
Box-Material	Polypropylene
Boxfarbe	Schwarz
Spannung	12 V
Kapazität	154 Ah
Kälteprüfstrom	1300 A/EN
L x B x H (mm)	513 x 189 x 223
Bodenleiste	B00
Schaltung	3
Anschlusspole	1
Gewicht	40.0 kg
Stück/Palette	24
Ausführung	G+G (gefüllt und geladen)

Bodenleiste **B00**



Schaltung **3**

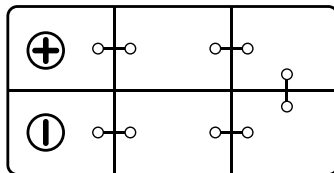

Anschlusspole **1**

